

Заклепка многозажимная

Тип **SSMG C**

Потайной борт

Углеродистая сталь / Углеродистая сталь

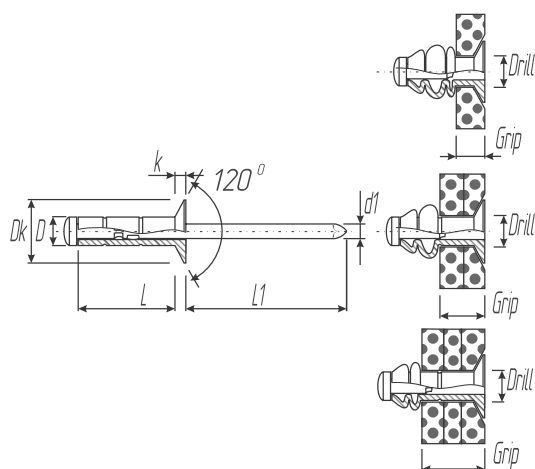

D, мм +0,08/-0,15	L, мм	Dk, мм	k, мм	d1, мм max	L1, мм min	Drill, мм	Grip, мм	H	H	Артикул
3,2	8,0	6,3	1,3	2,3	25	3,3	1,0-4,0	1000	1200	SSMG 3208C
	10,0						2,4-6,0			SSMG 3210C
	12,0						1,5-8,0			SSMG 3212C
	14,0						3,5-9,5			SSMG 3214C
	16,0						5,5-11,5			SSMG 3216C
4,0	8,0	7,5	1,7	2,9	27	4,1	1,0-3,5	1500	2000	SSMG 4008C
	10,0						1,5-5,0			SSMG 4010C
	12,0						3,5-7,0			SSMG 4012C
	14,0						1,5-9,0			SSMG 4014C
	16,0						3,5-11,0			SSMG 4016C
4,8	10,0	9,0	1,8	3,4	27	4,9	1,5-4,5	2400	2900	SSMG 4810C
	12,0						2,0-6,5			SSMG 4812C
	14,0						3,0-8,5			SSMG 4814C
	16,0						3,0-10,5			SSMG 4816C
	18,0						5,0-12,5			SSMG 4818C